



*interesting engineering for life..™*



# MIXER

**Prism Pharma Machinery®**

An ISO 9001 - 2015 Certified Company



### Greetings,

Prism Pharma Machinery founded in 2003 and has been manufacturing process equipments for process of Powder, Liquid & Semi Liquid in application in Pharmaceuticals, Biotech, Nutraceuticals, Cosmetics, Foods, Dairy, Bakery, Confectionery, Agro Chemical, Chemicals, Herbals, Paints, Ceramics & Catalysts for production, pilot & lab scale batch size.

Prism Pharma Machinery have wide range of equipments for processing for drying, granulating, mixing, milling, blending, tableting, coating, pelletizing, homogenizing, material conveying & cleaning as well as process integration and process automation service. Prism focuses on specialized mechanical engineering, especially process engineering and automation engineering by applies innovative technology approach and quality standard. We obtained the ISO 9001:2015 certificate and CE certificate for our products.











We sincerely would like express our thanks to our customers for supporting and affection. Prism has been and will be working more closely with all its precious customers and partner companies, keeping deep in mind the fact that sharing efforts makes sharing fruits.

Thanks you.....

Prism Pharma Machinery



## Contents

	High Shear Mixer Granulator-HSMG / Rapid Mixer Granulator - RMG	4
	Paddle Mixer Blender	6
	Ribbon Mixer Blender	8
	Mass Mixer	10
	Continuous Paddle Mixer Blender : Simplex Mixer	11
	“Z” Blade Sigma Mixer- Kneader Mixer –Sigma Mixer Extruder	12
	Octagonal Blender	14
	Double Cone Blender	15
	“V” Shape Mixer Blender	16
	Bin Blender – IBC Bin Blender	17
	Container Tumbler Blender	18



## High Shear Mixer Granulator-HSMG / Rapid Mixer Granulator - RMG

### High Performance Mixing and Wet Granulation Process Technik

#### Application & Process :

The High Shear Mixer Granulator is used for process of fast dry & wet mixing, homogenizing, humidifying and granulating of the powder in pharmaceuticals, chemicals, cosmetics, foods, plastics, and general mixing industries.

The High Shear Mixer Granulator is performs dry mixing & wet granulating by basic design of the special four arm of the mixing impeller and sequences of the mixing process in the cylindrical mixing drum with rounded connection to the base plate, achieve another special effect. The mixing process runs without varying pressure zone in the volume of mixing product. Separately driven multiple choppers can effectively intensify the mixing result in particular when liquid or paste components are added. During humidifying and granulating process of the products the chopper controls and regulates the granular spectrum and structure of the granules according to the product, chopper shape and time. The HSMG system requires only small quantities of granulating liquid or pastes to obtain the required granulate structure. This reduces the amount of drying energy required.



## Paddle Mixer Blender

### Uniform Fluidized Optimum Mixing Process Technik

#### Application & Process :

The Paddle Mixer Blender is designed for uniformly wet & dry mixing and blending technology provides the ideal environment for effectively optimum mixing a wide distribution of particle size and bulk densities without segregation of powder, granuls, short fiber, moist solids and liquids together with pasty substances up to and including highly viscous masses in pharmaceuticals, chemicals, herbals, cosmetics, foods, pesticides, detergents, and plastics industries etc.

Optimum mixing achieved through fluidization by combination of defined geometry lifting action with multi zoned, triple paddle stirrer rotor turning about 80 % faster than other mixer and Ribbon blender. During mixing process fluidization assures homogeneous mixing independent of large range of particle size, shape or density in short time. The paddles are positioned to move the material in opposing lateral directions as well as radically. The mixer consists of a rigid fabricated structure motor, gear box, mixing U-shaped horizontal drum and paddle type stirrer with adjustable pressure shaft sealing with air purging.

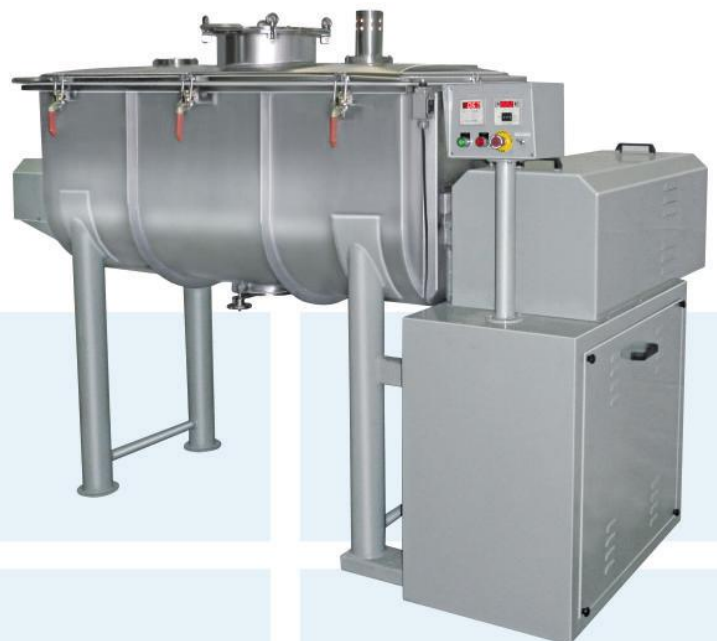



**Salient Features :**

- Design is cGMP with product contact parts AISI 316.
- Mixing technology provides ideal & effective mixing.
- Fluidization assures homogeneous mixing independent of large range of particle size, shape or density.
- Able to mix in approximately 30-60 seconds for dry applications.
- Inner & outer paddles on the triple action multi-zone paddle rotor.
- Minimum heat generated & high particle movement.
- Extremely gentle with fragile ingredients.
- Fast, even liquid addition and coating by spraying system.
- Ideal for agglomerating and no over mixing.
- Shaft seal with air purging and adjustable pressure.

**Optional Features :**

- Variable speed by VFD.
- Chopper blade assembly.
- Liquid spray coating system.
- Jackets for heating & cooling.
- Vacuumize operation.
- PLC controls with HMI touch screen.
- Flame proof electrical.

**Safety Features :**

- Total drive transmission system enclosed.
- Top lid with limit switch.
- Overload protection and emergency stop.

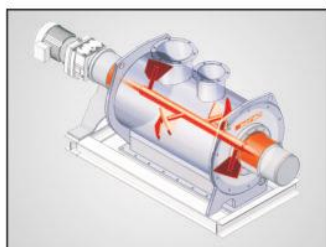

Machine assembly



Paddle blade stirrer



Spraying nozzle



Chopper blade

**Technical Specifications**

Model	Capacity Working			Motor HP		Stirrer RPM		Container Size in mm		
	Cub ft.	Liter	Kg.	Light	Heavy	Mixing	Drying	L	W	H
PPB-50	3.75	100	50	1.5	2	60	30	500	850	700
PPB-70	5	152	71	2	3	60	30	550	920	720
PPB-100	7.5	200	100	3	5	60	30	600	1100	800
PPB-140	10	283	140	5	5	60	30	660	1220	840
PPB-200	15	400	200	5	7.5	60	30	730	1300	920
PPB-280	20	566	280	7.5	10	60	30	810	1370	990
PPB-400	30	850	425	10	15	60	30	940	1680	1120
PPB-550	40	1132	560	15	20	60	30	1070	1830	1250
PPB-700	50	1416	705	20	30	60	30	1140	1980	1320
PPB-1000	75	2124	1060	25	40	40	30	1270	2290	1450
PPB-1400	100	2832	1415	30	50	40	30	1370	2440	1550
PPB-1700	125	3540	1770	30	50	40	30	1520	2740	1700
PPB-2100	150	4248	2125	40	60	40	30	1680	2740	1850
PPB-2500	175	4855	2500	40	60	40	30	1680	3050	1850
PPB-2800	200	5664	2830	50	75	40	30	1830	3050	2000
PPB-3500	250	7080	3500	50	75	40	30	1830	3350	2000
PPB-4000	300	8495	4250	75	100	40	30	2030	3660	2210

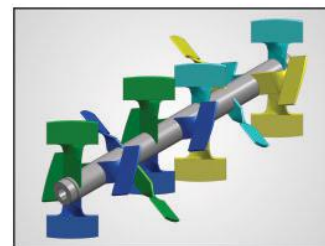

Paddle Blade

## Ribbon Mixer Blender

### Uniform Dry & Wet Mixing Process

#### Application & Process :

Ribbon mixer blender mixer is used for uniformly dry & wet mixing and blending applications in the pharmaceuticals, chemicals, cosmetics, foods, pesticides, detergents, and plastics industries ect.

The Ribbon Blender comprises of a U-shaped horizontal trough, specially designed double helical ribbon agitator, rigid fabricated structure motor, gear box. In operation, material is filled to the top of the outer ribbon. The shaft rotates at relatively low speed and the moving ribbons push the material back and forth mixing it. The outer ribbon rotation displaces the material from the ends to the center while the inner ribbon rotations move the material from the center to the ends. This counter-current action results in homogenous blending. Mixing is achieved in 15 to 20 minutes with 90 to 95 % or better homogeneity. The bottom discharge is provided for unloading of the material and easy cleaning of the mixing drum. Specially designed self adjusting sealing arrangement of unique design is provided to ensure that no black particle enters into the mixing drum.





**Salient Features :**

- Design is cGMP with product contact parts AISI 316.
- Uniform dry & wet mixing process.
- Container shape & stirrer gives sufficient continuous movement to the powder.
- Minor ingredients are dispersed homogeneously.
- Double or triple action with blending.
- Extremely gentle with fragile ingredients.
- Fast, even liquid addition and coating by spraying system.
- Ideal for agglomerating and no over mixing.
- Shaft seal with air purging and adjustable pressure.
- Rigid direct drive through gear box with motor.

**Optional Features :**

- Variable speed drive.
- Liquid spray coating system.
- Jacket for heating & cooling.
- Vacuumize operation.
- PLC controls with HMI touch screen.
- Explosion proof electrical.

**Safety Features :**

- Total drive transmission system enclosed.
- Top lid with limit switch.



Flush discharge gate



Ribbon blade stirrer

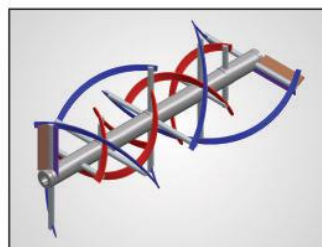

Ribbon blade design



Charging gate

**Technical Specifications**

Model	Capacity Working			Stirrer RPM	Motor Rating		Container Dimension			Over all Dimension		
	Total Liter	Working Liter	Loading in Kg.		Light HP	Medium HP	Length mm	Width mm	Height mm	Length mm	Width mm	Height mm
PRMD-50	75	50	25	40	1.0	1.0	750	275	400	1750	950	1700
PRMD -100	150	100	50	40	1.0	1.5	850	400	500	1900	1175	1850
PRMD -200	300	200	100	40	2.0	3.0	1250	450	600	2500	1300	1950
PRMD -300	450	300	150	40	3.0	5.0	1500	500	650	2800	1400	2050
PRMD -400	600	400	200	40	5.0	7.5	1700	550	700	3100	1450	2100
PRMD -500	800	500	250	40	5.0	7.5	1800	600	800	3400	1525	2100
PRMD -750	1100	750	325	30	7.5	10.0	1900	650	900	3550	1550	2200
PRMD -1000	1500	1000	500	30	10.0	12.0	1900	750	1050	3670	1650	2280
PRMD -1250	1900	1250	625	30	12.5	15	2100	850	1100	3850	1825	2450
PRMD -1500	2250	1500	1250	30	15	20	2250	900	1200	4000	1950	2500
PRMD -2000	3000	2000	1000	30	20	25	2500	1000	1350	4300	2050	2600
PRMD -3000	4500	3000	1500	30	30	40	2700	1100	1500	4780	2150	2800
PRMD -5000	7500	5000	2500	30	40	50	3500	1250	1700	6300	1900	3000
PRMD -7500	11000	7500	3750	30	50	60	3800	1600	2100	6350	2000	3500
PRMD-10000	15000	10000	5000	30	60	75	4000	1850	2250	6500	2150	3650



## Mass Mixer

### Uniform Mixing Process Technik for Dry & Wet Granulation

#### Application & Process :

The Mass Mixer is designed for uniformly mixing of dry and wet material and especially suitable for powder of pharmaceuticals, foods, herbals, agro chemicals & ahemicals in industries etc.

The Mass Mixer consists of a rigid fabricated structure motor, gear box, mixing drum, stirrer and tilting device. Specially designed self adjusting sealing arrangement of unique design is provided to ensure that no black particle enters into the mixing drum. The material under mixing process can be monitored through acrylic dust cover and it controls dusting and contaminations. The tilting device is provided to make easy the unloading of the material and easy cleaning of the mixing drum.

#### Salient Features :

- Design is cGMP-current good manufacturing practices.
- All contact parts AISI 316 & non contact parts AISI 304.
- Uniform mixing with paddle blade stirrer.
- Self adjusting sealing arrangement to avoid entire black particles.
- Tilting device for easy unloading and cleaning.
- The interlocked acrylic covers of product container, enclosed drive & overloads relay protection.

#### Safety Features :

- Closed drive, interlock top lid & overload protection.
- Optional features: explosion proof motor.

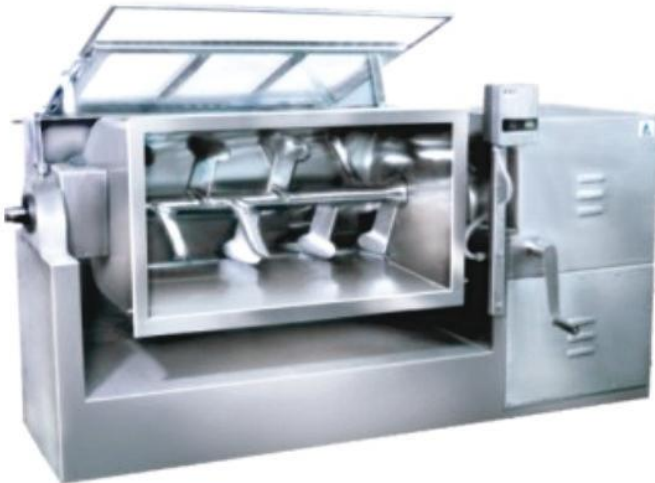

### Technical Specifications

Model	PMM-50	PMM-100	PMM-150	PMM-200	PMM-300	PMM-500
Capacity in Kg	50	100	150	200	300	500
Brim Volume in Liter.	100	200	300	400	600	1000
Working Volume in Liter.	80	160	240	320	580	800
Stirrer RPM	30	30	30	30	30	30
Electric Motor HP / kw	3/2.25	5/3.75	7.5/5.6	7.5/5.6	10/7.5	15/11.25

# Continuous Paddle Mixer Blender : Simplex Mixer



## Continuous Effective Mixing Process Technik

### Application & Process :

The single shaft continuous Paddle Mixer Blender is designed for uniformly wet & dry mixing and blending technology provides the ideal environment for effectively optimum mixing a wide distribution of particle size and bulk densities without segregation of powder, granular, short fibered, moist solids and liquids together with pasty substances up to and including highly viscous masses in the pharmaceutical, chemical, herbal, cosmetic, food, pesticides, detergents, and plastics industries. The mixer produces high quality intermediate and end product with homogeneity. Extremely fragile products are handled very gently. Micro ingredients are accurately mixed.

- Dry solid blending
- Solid and liquid blends
- Coating
- Granulation
- Flavoring
- Premixing for extrusion

Single shaft continuous mixer makes material rotate along with main shaft. Mixer agitator breaks material and mix material in the mean time. It is suitable for mixer material with different density, size, etc. Continuous mixer depends on continuous and proportioned feeding, so should be combined with feeding system. During mixing process fluidization assures homogeneous mixing independent of large range of particle size, shape or density. The paddles are positioned to move the material in lateral directions as well as radically. The mixer consists of a rigid fabricated structure motor, gear box, U-shaped horizontal drum and paddle type stirrer. option available for variable drive for agitator, liquid spraying system, jacket product container for heat & cool and explosion proof motor.

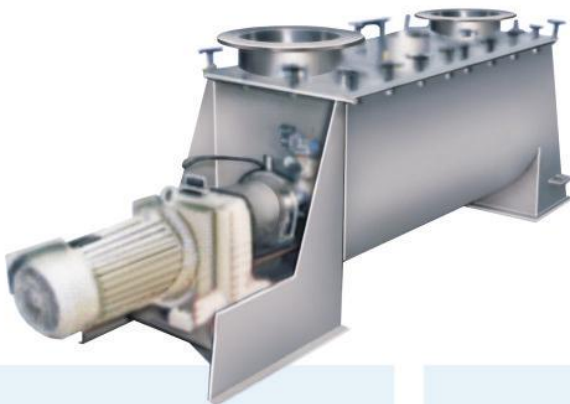
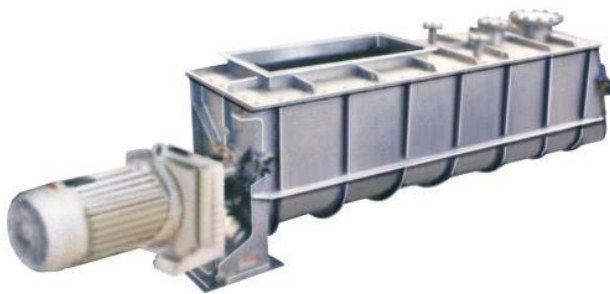

### Technical Specifications

Model	Nominal Capacity Tons/ hour	Nominal Motor HP	Shaft Length in cm	Container Width in cm	Height in cm
PCM-180	5	5	180	40	60
PCM-250	7	5	250	40	60
PCM-300	9	7.5	300	40	60
PCM-365	10	7.5	365	40	60
PCM-425	12	10	425	40	60



## “Z” Blade Sigma Mixer- Kneader Sigma Mixer Extruder

### 'Z" Blade - Sigma Mixer- Kneader



#### Uniform Kneading, Mixing & Extruding Process

##### Application & Process :

The Sigma Mixer is used for mixing and kneading of highly viscous mass, sticky and dough like product, mixing of pastes, gum, rubber & heavy plastic masses, applications in foods, rubbers, pharmaceuticals, confectionery, chemicals & agro chemical.

##### Sigma Mixer :

The sigma kneader is a double arm mixer, the two “Z” blade rotate towards each others at same or different speed inside a W- shaped product container. The kneader machine with two horizontally arranged 'z' blades, which are deeply geared into one another and strip themselves reciprocally. Each blade moves the material in opposite direction thereby providing excellent cross mixing of all raw materials. The blades pass the trough walls and each other at close clearances resulting in good mixing by shearing and tearing action that is beneficial to the size reduction of solids. Selection of appropriate blade shape and speeds result in excellent mixing

##### Salient Features :

- Mixing & kneading of high viscous materials with a combined action of bulk movement, kneading, stretching folding, dividing and recombining.
- 'W' shape container with double 'Z' blade with different speed.
- Heavy duty drive with gear box motor, coupling & helical gear.
- Hydraulic lifting for unload.

##### Option features :

- Jackets for heating and cooling.
- Vacuum mixing & drying.
- Liquid spray system.
- Explosion proof motor.

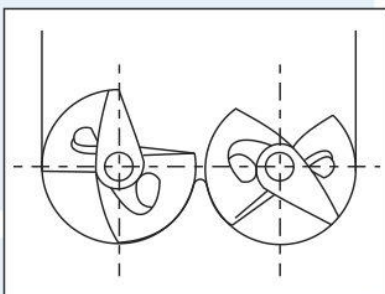

Mixing trough with kneading blades



Sigma - or Z-form blade



Paddle blade



## Z' Blade Sigma Mixer Extruder

### Sigma Mixer Extruder :

The Extruder Sigma Mixer is designed to handle difficult to discharge products such as hot melts and butyl sealants, as well as other medium to high viscosity pastes. This type of mixer combines the action of the double arm sigma blade mixer with an extrusion screw placed in the lower part of the mix trough. During mixing, the extrusion screw is run in reverse which imparts a third mixing action on the product, increasing mixing efficiency.

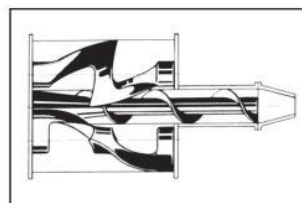

Mixing trough with extrusion screw

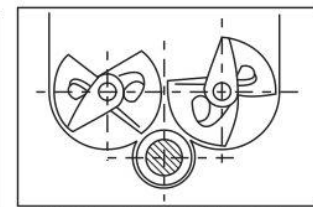

Mixing trough with extrusion screw

### Technical Specifications

Model	Total Capacity	Working Capacity	Motor Rating		Extruder	Container Dimension			Over all Dimension		
	Liter	Liter	Standard HP	Heavy HP		HP	Length mm	Width mm	Height mm	Length mm	Width mm
PSMEXT-5	8	3-5	1	2	2-3	200	200	200	650	500	800
PSMEXT-50	75	35-50	5	7.5	3-5	450	450	450	1650	1200	1500
PSMEXT-100	150	70-100	10	15	5-7.5	600	600	550	2000	1700	1850
PSMEXT-150	225	110-150	15	20	7.5-10	650	650	600	2200	1800	1950
PSMEXT-200	300	150-200	20	25	10-15	750	750	700	2400	1850	2000
PSMEXT-300	450	225-300	25	30	10-15	850	850	750	2700	1950	2050
PSMEXT-400	600	300-400	30	40	15-20	900	900	800	2800	2100	2100
PSMEXT-500	800	400-500	40	50	15-20	1000	1000	875	3000	2150	2250
PSMEXT-750	1100	500-750	50	60	15-20	1150	1150	1000	3300	2200	2350
PSMEXT-1000	1400	700-1000	60	75	75	1250	1250	1150	3500	2250	2500

## Octagonal Blender

### Effective Process Technik of Uniform Mixing, Lubricating & Blending of Dry Powder & Granules



#### Application & Process :

Blenders are used for mixing, lubricating and blending in pharmaceuticals, nutraceuticals, foods, chemicals, cosmetics, ceramics, pesticide, plastics and other allied industries etc.

The octagonal shape blenders have six corner of product container for more tumbler effect to the material for fast and homogenizing mixing. It can perform homogeneously dry mixing of free flowing powders, granules requiring low shearing force, mixing and blending of particles with rapid intermixing of particles irrespective of varying specific gravities.

#### Salient Features :

- Design is cGMP with product contact parts AISI 316.
- Octagonal shape product container is ideal for dry mixing for lubrication of granules and homogenization mixing.
- Fixed baffles provided for lumps breaking.
- "A" type rigid structure with enclosed gear motor drive.
- Charging hole with hinged lid & discharge with butterfly valve.
- Electric control panel with cycle time.

#### Safety Features :

- Safety reeling with limit switch.
- Overload protection and emergency stop.

#### Optional Features :

- Loading & unloading by product container with jacking trolley.
- Loading by IPC bin with loader.
- Variable speed by VFD.
- PLC controls with HMI touch screen.
- Explosion proof electrical.
- Inline milling, sifting with vacuum conveying system.

#### Technical Specifications

Model	Brim Volume	Working Volume	Loading Capacity	Container Speed	Motor
	Liter	Liter	Kg.	RPM	HP
POB-50	60	50	25	12	1
POB-60	72	60	30	12	1
POB-100	120	100	50	12	1.5
PVB-120	150	120	60	12	1.5
POB-200	240	200	100	12	2
POB-240	300	240	120	12	2
POB-300	360	300	150	12	3
POB-500	600	500	250	10	5
POB-1000	1200	1000	500	8	7.5
POB-1500	1800	1500	750	8	10
POB-2000	2400	2000	1000	8	15
POB-3000	3600	3000	1500	8	20
POB-5000	6000	5000	2500	8	25

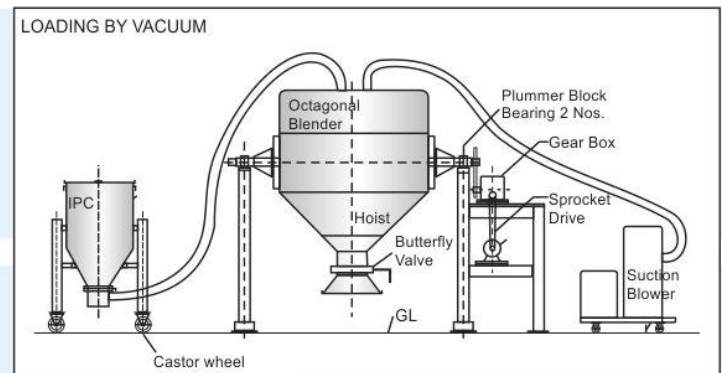



## Double Cone Blender

### Effective Process Technik of Uniform Mixing, Lubricating & Blending of Dry Powder & Granules



#### Technical Specifications

Model	Brim Volume	Working Volume	Loading Capacity	Container Speed	Motor
	Liter	Liter	Kg.	RPM	HP
PDB-50	60	50	25	12	1
PDB-60	72	60	30	12	1
PDB-100	120	100	50	12	1.5
PDB-120	150	120	60	12	1.5
PDB-200	240	200	100	12	2
PDB-240	300	240	120	12	2
PDB-300	360	300	150	12	3
PDB-500	600	500	250	10	5
PDB-1000	1200	1000	500	8	7.5
PDB-1500	1800	1500	750	8	10
PDB-2000	2400	2000	1000	8	15
PDB-3000	3600	3000	1500	8	20
PDB-5000	6000	5000	2500	8	25

#### Application & Process :

Blenders are used for mixing, lubricating and blending in pharmaceuticals, nutraceuticals, foods, chemicals, cosmetics, ceramics, pesticides, plastics and other allied industries etc.

The double shape blenders have long two corner of product container for more rubbing and tumbler effect to the material for fast and homogenizing mixing. It can perform homogenously dry mixing of free flowing powders, granules requiring low shearing force, mixing and blending with rapid intermixing of particles irrespective of varying specific gravities.

#### Salient Features :

- Design is cGMP with product contact parts AISI 316.
- Double cone shape product container for ideal dry mixer for lubrication of granules and homogenization mixing.
- Fixed baffles provided for lumps breaking.
- A" type rigid structure with enclosed gear motor drive.
- Charging hole with hinged lid & discharge with butterfly valve.
- Electric control panel with cycle time.

#### Safety Features :

- Safety reeling with limit switch.
- Overload protection and emergency stop.

#### Optional Features :

- Loading & unloading by product container with jacking trolley.
- Loading by IPC bin with loader.
- Variable speed by VFD.
- PLC controls with HMI touch screen,
- Explosion proof electrical.
- Inline milling, sifting with vacuum conveying system.

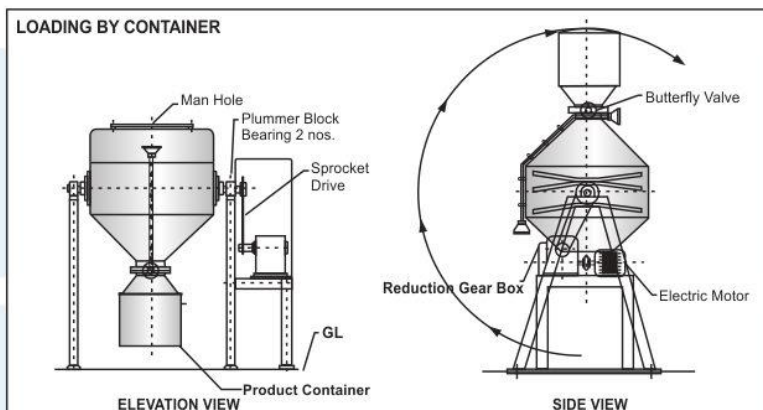



## “V” Shape Mixer Blender

### Effective Process Technik of Uniform Mixing, Lubricating & Blending of Dry Powder & Granules

#### Application & Process :

Blenders are used for mixing, lubricating and blending in pharmaceuticals, nutraceuticals, foods, chemicals, cosmetics, ceramics, pesticide, plastics and other allied industries etc.

The product containers have “V” shape so it crated continuously split and recombines of the material with more tumbler and friction effect to the material for fast and homogenizing mixing. It can perform homogeneously dry mixing of free flowing powders, granules requiring low shearing force, mixing and blending of particles with rapid intermixing of particles irrespective of varying specific gravities. The material is loaded into the “V” shape blender drum.

#### Salient Features :

- Design is cGMP with product contact parts AISI 316.
- ‘V’ shape product container for ideal dry mixer for lubrication of granules and homogenization mixing.
- Fixed baffles provided for lumps breaking.
- “A” type rigid structure with enclosed gear motor drive.
- Charging hole with hinged lid & discharge with butterfly valve.
- Electric controls panel with cycle time.

#### Safety Features :

- Safety realing with limit switch.

#### Optional Features :

- Intensifier with variable speed by VFD.
- Interchange container type model.
- Different option for loading & unloading.
- Variable speed by VFD.
- PLC controls with HMI touch screen,
- Explosion proof electrical.



### Technical Specifications

Model	Brim Volume	Working Volume	Loading Capacity	Container Speed	Mixing Motor	Intensifier Bar	Intensifier Motor	Container Diameter
	Liter	Liter	Kg.	RPM	HP	RPM	HP	mm
PVB-50	60	50	25	12	1	650	1	300
PVB-60	72	60	30	12	1	650	1	300
PVB-100	120	100	50	12	1.5	650	1	400
PVB-120	150	120	60	12	1.5	650	1	400
PVB-200	240	200	100	12	2	650	1.5	500
PVB-240	300	240	120	12	2	650	1.5	500
PVB-300	360	300	150	12	3	650	1.5	550
PVB-500	600	500	250	8	5	N.A.		600
PVB-1000	1200	1000	500	8	7.5			750
PVB-1500	1800	1500	750	8	10			850
PVB-2000	2400	2000	1000	8	15			1000
PVB-3000	3600	3000	1500	8	20			1200
PVB-5000	6000	5000	2500	8	25			1500

# Bin Blender - IBC Bin Blender



## Dust Free Effective Process Technik of Uniform Mixing, Lubricating & Blending of Dry Powder & Granules



Bin blenders or container tumblers are used mainly for blending of dry powders for tablet production and capsule, which facilitates better flow for tablets and capsules.

This is a closed contained, totally dust free single step transfer system. It can handle more than one size of bin. IBC bin is loaded in granulation room & transfer the same bin to loaded over to the blender for blending. The IBC bin locked in the resting frame in 15° then lifted by hydraulic system in 15° inclined position after that the IBC bin rotates for blending with 3 dimension action. This same container after blending loaded over the tablet press for unloading into the tablet press hoppers.

### Salient Features :

- Design is cGMP with product contact parts AISI 316.
- IBC blender is ideal for dry mixing of lubrication of granules and homogenization mixing and conveying of the material to further process.
- Interchangeable different capacity of IBC Bin.
- Closed and contained system for blending, storage & transfer.
- Totally dust free operation.
- Machine structure with drive through reduction gear motor.
- Hydraulic power pack system for lifting of product bin for mixing.
- Cage for locking bin to lift and rotate and interlock with drive.
- Charging with quick opening lid & discharge with butterfly valve.
- Electric control panel with cycle time

### Safety Features :

- Safety reeling with interlock.
- Overload relay protection & emergency stop button.

### Optional Features :

- Interchangeable product container
- Variable speed by VFD.
- PLC controls with HMI touch screen,
- Explosion proof electrical.

## Technical Specifications

Model	Brim Volume	Working Capacity		Container Speed	Mixing Motor	Hyd. Power Pack
	Liter	Liter	kg.	RPM	HP	HP
PBB-50	60	50	25	10	1	1
PBB-60	72	60	30	10	1	1
PBB-100	120	100	50	10	1.5	1
PBB-120	150	120	60	10	1.5	1
PBB-200	240	200	100	10	2	1.5
PBB-240	300	240	120	10	3	1.5
PBB-300	360	300	150	10	3	1.5
PBB-500	600	500	250	8	5	2



## Container Tumbler Blender

### Dust Free Effective Process Technik of Uniform Mixing, Lubricating & Blending of Dry Powder & Granules

#### Application & Process :

Tumbler blenders or IBC container tumblers are used mainly for blending of dry powders for tablet production and capsule, which facilitates better flow for tablets and capsules.

This is a closed contained, totally dust free single step transfer system. It can handle more than one size of IBC container. IBC bin is loaded in granulation room & transfer the same bin to loaded over to the blender for blending. The IBC bin locked in the resting frame in 15° then lifted by hydraulic system to up ward for moving height after that the IBC bin rotates for blending. This same IBC container after blending is raised over the tablet press for unloading in to the tablet press hoppers.

#### Salient Features :

- Design is cGMP with product contact parts AISI 316.
- IBC bin blender is for ideal for dry mixing for lubrication of granules and homogenization mixing and conveying of the material to further process.
- Interchangeable different capacity of IBC bin.
- Closed and contained system for blending, storage & transfer.
- Totally dust free operation.
- Pillar structure with movable drive unit.
- Hydraulic power pack system for lifting of bin for mixing.
- Cage for locking bin to lift and rotate and interlock with drive.
- Charging with quick opening lid & discharge with butterfly valve.
- Electric controls panel with cycle time.

#### Safety Features :

- Safety realing with interlock.
- Overload relay protection & emergency stop button.

#### Optional Features :

- Interchangeable product container.
- Variable speed by VFD.
- PLC controls with HMI touch screen,
- Explosion proof electrical.









































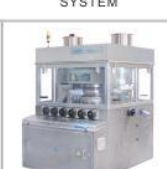









### Technical Specification

Model	Brim Volume	Working Capacity		Container Speed	Mixing Motor	Hyd. Power Pack
	Liter	Liter	kg.	RPM	HP	HP
PBB-50	60	50	25	10	1	1
PBB-60	72	60	30	10	1	1
PBB-100	120	100	50	10	1.5	1
PBB-120	150	120	60	10	1.5	1
PBB-200	240	200	100	10	2	1.5
PBB-240	300	240	120	10	3	1.5
PBB-300	360	300	150	10	3	1.5
PBB-500	600	500	250	8	5	2

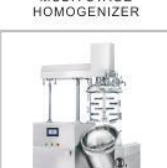

# Production Scale Machinery for Powder, Liquid & Ointment

							
PADDLE VACUUM MIXER DRYER	ROTO CONE VACUUM DRYER	VACUUM TRAY DRYER	FLUID BED EQUIPMENT	TRAY DRYER	ROLL COMPACTOR	PASTE KETTLE	COMMUNITING MILL
							
CONE MILL	GRANULATOR	VIBRO SIFTER	BIN/CAGE BLENDER	OCTAGONAL BLENDER	DOUBLE CONE BLENDER	'V' SHAPE BLENDER	IPC/BIN LOADER
							
TIPPLER	SCREW CONVEYOR	IPC BIN	BASKET EXTRUDER	SPHERODIZER	AUTOCOATER	CONVENTIONAL COATING	COLLOID MILL
							
STIRRER	VACUUM CONVEYER SYSTEM	VIBRO DE-DUSTER	DUST EXTRACTOR	TABXPRESS-PTX	TABXPRESS-PUV	PTCMD4	PTCMB4
							
TABXPRESS-II	TABXPRESS-IV	LAB TABLET PRESS	LAB HSMG	LAB FBD	LAB MULTI MIL	LAB BLENDER	LAB AUTOCOATER
							
LAB RMG	LAB PLANETERI MIXER	LIQUID / SYRUP MANUFACTURING PLANT		MULTI STAGE HOMOGENIZER	FILTER PRESS	TELESCOPIC STIRRER	STORAGE TANK
							
VESSEL WITH INLINE HOMOGENIZER	OINTMENT / CREAM / GEL MANUFACTURING PLANT		OINTMENT/CREAM/PASTE/GEL MANUFACTURING PLANT		VACUUM HOMOGENIZER MIXER	CIP / WIP SYSTEM	BIN WASHING SYSTEM

## Prism's Global Presence

Middle East Country	African Country	USA & Latin USA Country	Asian Country	European Country	
UAE	Algeria	United state of America	India	Australia	Russia
Saudi Arabia	Nigeria	Mexico	Afghanistan	New Zealand	Macedonia
Egypt	Kenya	Peru	Nepal	Russia	Spain
Turkey	Malawi	Chile	Bangladesh	England	Slovenia Ukraine
Jordan	Ghana	Ecuador	Malaysia	Belarus	Italy
Oman	Congo	Colombia	Singapore	Belgium	
Iran	Uganda	Morocco	Thailand	Northern Poland	
Iraq	Ethiopia	El- Salvador	Vietnam	Sweden	
Syria	Tunisia	Canada	Hong Kong	Ireland	
Yemen	Zambia	Cuba	Myanmar	Finland	
Lebanon	South Africa		Sri Lanka	Bulgaria	
			Indonesia	Netherland	



The data and illustration in the document correspond to the technical level at the time of printing and do not constitute a part of any offer. The right to make alterations is reserved.



## Prism Pharma Machinery®

Manufacturer & Exporter of Pharmaceutical Machinery

Plot No. 3713, Phase-IV, G.I.D.C. Vatva, Ahmedabad - 382 445. (Gujarat) INDIA.

Tel. : +91-79-25841623, Mobile : +91 9825044789, 9375044789,

E-mail : mkt@prismpharmamachinery.com, sales@prismpharmamachinery.com

Website : [www.prismpharmamachinery.com](http://www.prismpharmamachinery.com)

UPM RAFLATAC